

Joint News Release

Date of Issue: 9 September 2016

Hairline Cracks on 11 First-Generation Sengkang-Punggol LRT Vehicles

1. As part of SBS Transit's fleet-wide inspection in July 2016, hairline cracks were discovered on 11 of the first-generation Sengkang-Punggol LRT (SPLRT) trains, or Light Rail Vehicles (LRVs). These affected LRVs have been in operation since the SPLRT started in 2003.
2. The hairline cracks which were found on the bogie frames do not compromise its weight bearing property. One of the core functions of the bogie frame is to support the guidance system of the LRV (refer to the Annex for the location of the crack and guidance system).
3. Nonetheless, as a precautionary measure, these 11 LRVs were immediately withdrawn from passenger service for replacement of the bogie frames. Six of the 11 LRVs have been restored and returned to service. The remaining five LRVs are expected to be reinstated by mid-October 2016. LRT services have not been affected as there are 57 LRVs in the SPLRT fleet, and a maximum of 36 trains are deployed at any one time. SBS Transit has also been inspecting all LRVs on a weekly basis for any new defects.
4. To determine the cause, a sample of the affected bogie frame was sent to the manufacturer, Mitsubishi Heavy Industry (MHI)'s R&D Centre in Japan for a detailed analysis. LTA and SBS Transit are working with MHI to redesign, strengthen and replace the bogie frame structures on all 57 LRVs. The detailed improvement timeline is being worked out, and MHI will bear the replacement costs. In addition, an independent assessor, TUV Rheinland, has established that the defects are not safety critical. MHI has made the same assessment.

For enquiries, please contact:

Sukhwinder Kaur Senior Manager, Media Relations Tel: 6396 1964/ 9651 7055 Email: media@lta.gov.sg	Cheryl Leow Assistant Manager, Media Relations Tel: 6396 1947/ 9829 1134 Email: media@lta.gov.sg
--	---

Grace Wu
Vice President, Corporate Communications
SBS Transit
Tel: 63837207 / 97816280
Email: gracewu@sbstransit.com.sg

Location of Crack on Bogie Frame

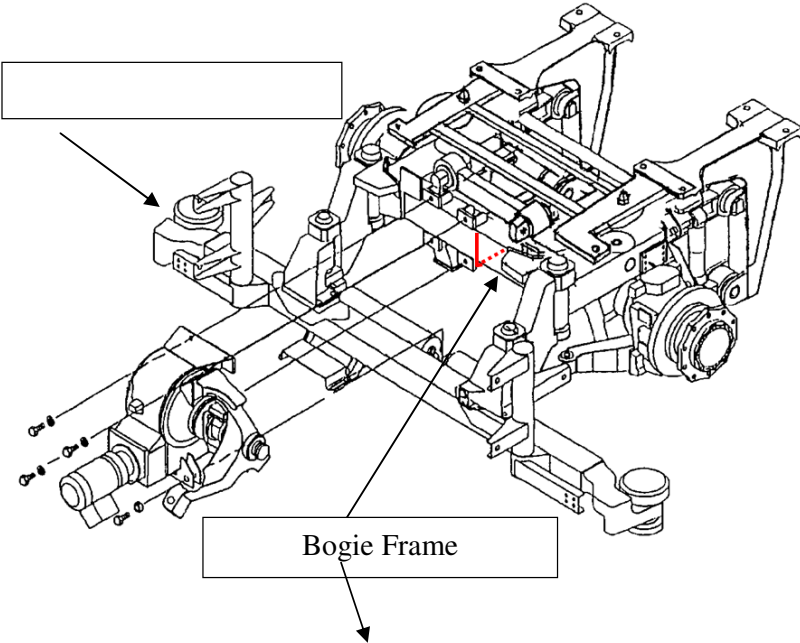

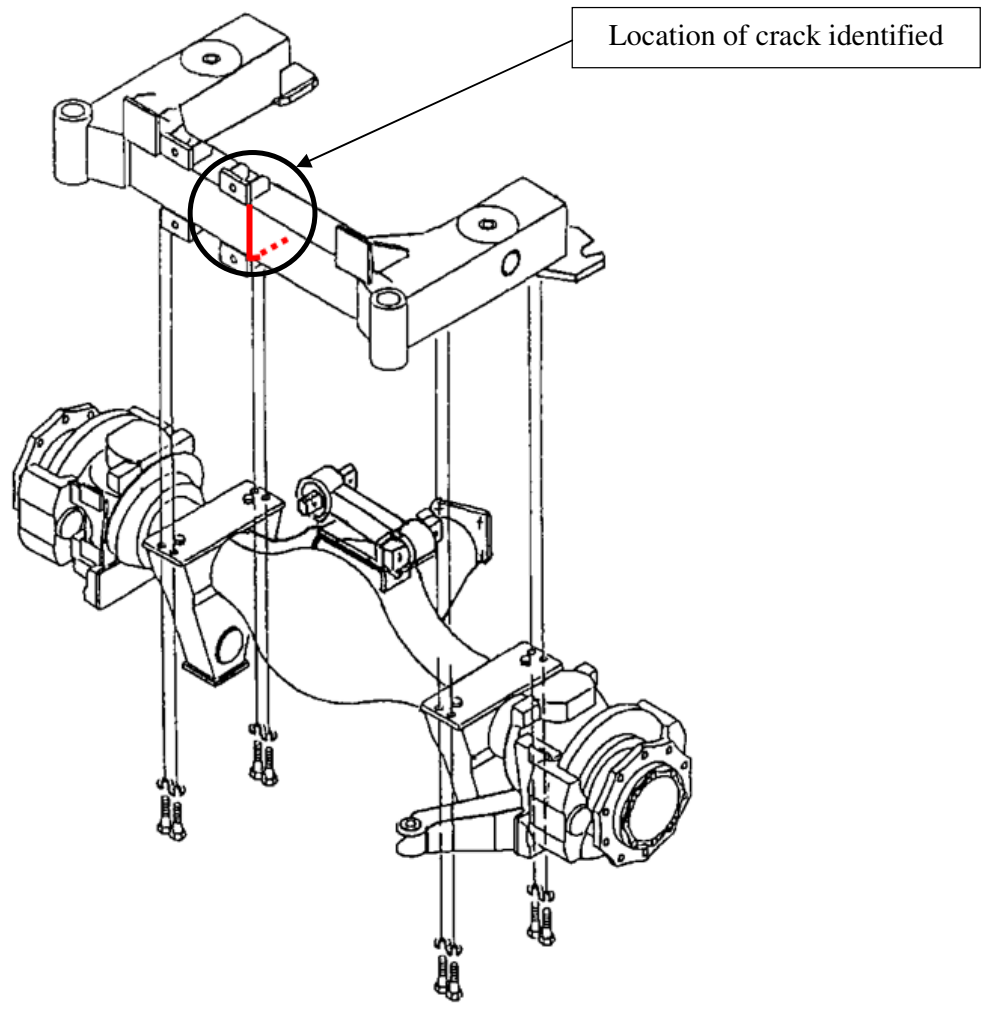

Photo of Bogie Frame Cracks

