

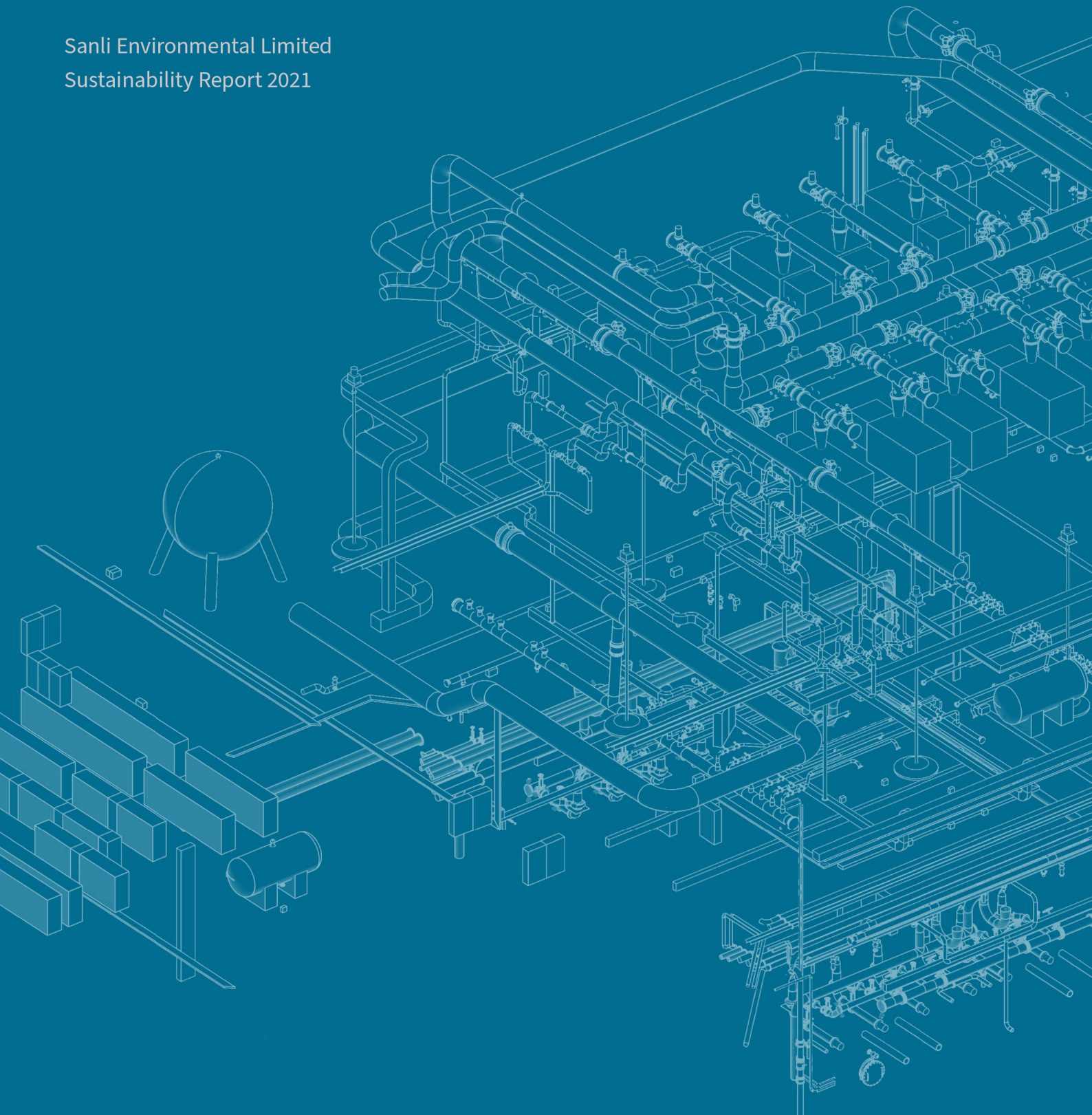

# Re-engineering Our Processes Generating Efficiencies

Sanli Environmental Limited  
Sustainability Report 2021



# CONTENTS

1.	Message from Our Board of Directors	01
2.	Organisational Profile	02
3.	Sustainability Approach	03
4.	Stakeholders And Materiality	05
5.	Economic	08
6.	Environmental	09
7.	Social	10
8.	Governance	15
9.	Gri Standards Content Index	16

This sustainability report has been reviewed by the Company's Sponsor, SAC Capital Private Limited (the "Sponsor"). This sustainability report has not been examined or approved by the Singapore Exchange Securities Trading Limited (the "SGX-ST") and the SGX-ST assumes no responsibility for the contents of this sustainability report including the correctness of any of the statements or opinions made or reports contained in this sustainability report.

The contact person for the Sponsor is Mr David Yeong (Telephone number: +65 6232 3210), at 1 Robinson Road, #21- 00 AIA Tower, Singapore 04854

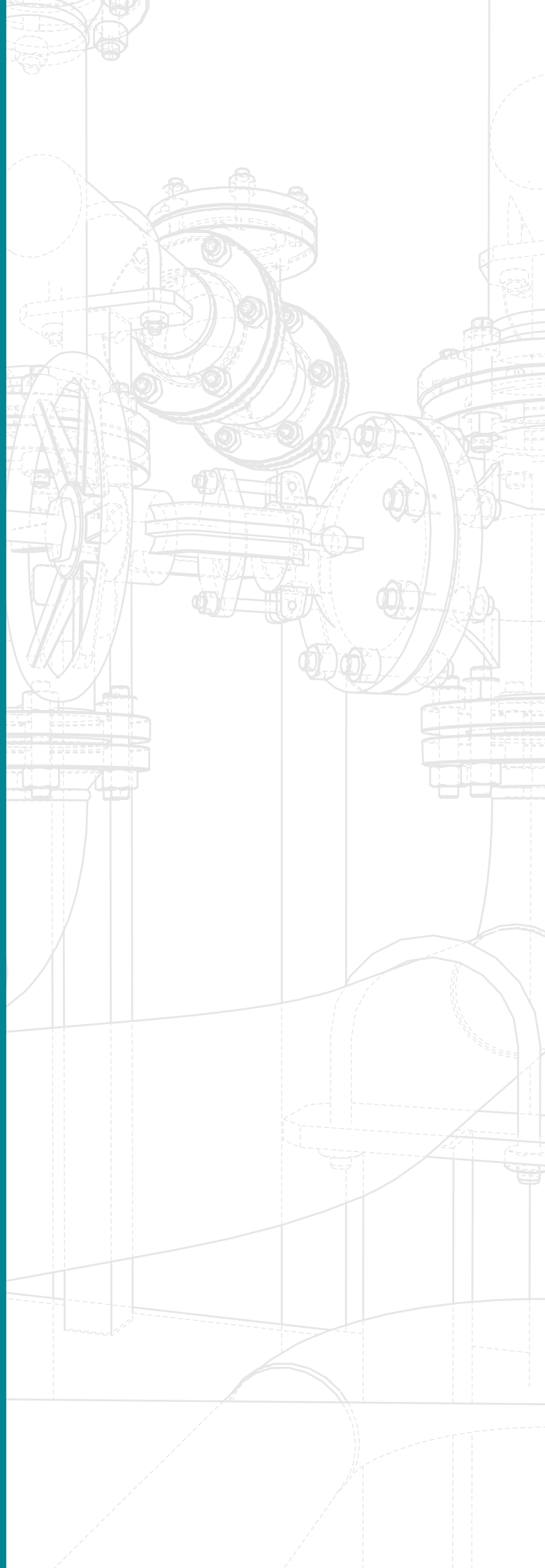

# MESSAGE FROM OUR BOARD OF DIRECTORS

We are pleased to present our annual Sustainability Report (“SR”) of Sanli Environmental Limited (“Sanli”, the “Company”, and together with its subsidiaries, the “Group”) for the financial year ended 31 March 2021 (“FY2021”).

The Group is committed to continually consider material economic, environmental, social and governance (“EESG”) topics as part of our core business strategy. The Board of Directors (“Board”) and senior management (“Management”) remain committed to establish and maintain an effective sustainability management framework, which is supported by underlying internal controls, risk management practices, clear accountability and reporting process. The Board evaluates and considers ESG risks and opportunities relevant to the Group during the formulation of overall business strategy, objectives and performance measurements.

Sustainability is a part of the Group’s wider strategy to create long-term value for all its stakeholders. As such, the key material EESG factors for the Group have been identified and cautiously reviewed by the Management annually. The data and information provided in this report have not been verified by an independent third party. The Management has relied on internal data monitoring and verification to ensure accuracy of data and information.

The Board oversees the Management and monitors the materiality of the Group’s EESG factors, in order to set targets for the Group’s material EESG factors. The objectives and the Group’s sustainability performance are taken into consideration by the Board in determining the Group’s strategic direction and policies.

## REPORTING PERIOD, SCOPE AND FRAMEWORK

This report has been prepared with reference to the Global Reporting Initiative (“GRI”) Standards - Core option, and on a “comply or explain” basis in accordance with Rule 711B and Practice Note 7F of the Singapore Exchange Securities Trading Limited (“SGX-ST”) Section B: Rules of Catalist (“Catalist Rules”). Sanli has chosen the GRI framework as it is an internationally recognised reporting framework that covers a comprehensive range of sustainability disclosures. This report highlights the key EESG related initiatives and strategies for the Group’s operations in Singapore for the 12-month period, from 1 April 2020 to 31 March 2021. For the purpose of this report, the Company has decided to focus on the operations in Singapore and exclude the subsidiaries with operations in Malaysia and Myanmar due to their revenue contribution. The Group will reevaluate the scope in the next report.

The report includes information on the Group’s operations in Singapore from the following entities:

- Sanli Environmental Limited
- Sanli M&E Engineering Pte Ltd
- Sanli E&C Pte Ltd

This report summarises the expectations from various stakeholders, general business environment that the Group is operating in and what the Group has done in order to ensure the sustainability of the Group.

The information disclosed in the SR, read together with the information in the Group’s annual reports will provide the reader with a holistic view of the operations of our Group. We will strive to maintain and/or improve the standards of the various EESG factors reported where appropriate and practicable, in accordance with the business activities of the Group in the future.

To further ensure the accuracy of the data and information provided in this report, we will consider seeking external independent assurance review in the future.

## FEEDBACK

We welcome feedback from our stakeholders with regards to our sustainability efforts as this enables us to consistently improve our policies, systems and results. Please send your comments and suggestions to michael.law@sanli.com.sg. There was no feedback received for FY2021.

## ACCESS

No hard copies of this Sustainability Report have been printed as part of our efforts to promote environmental conservation. You may visit SGX website or our company website <https://www.sanli.com.sg> for our Sustainability Report.

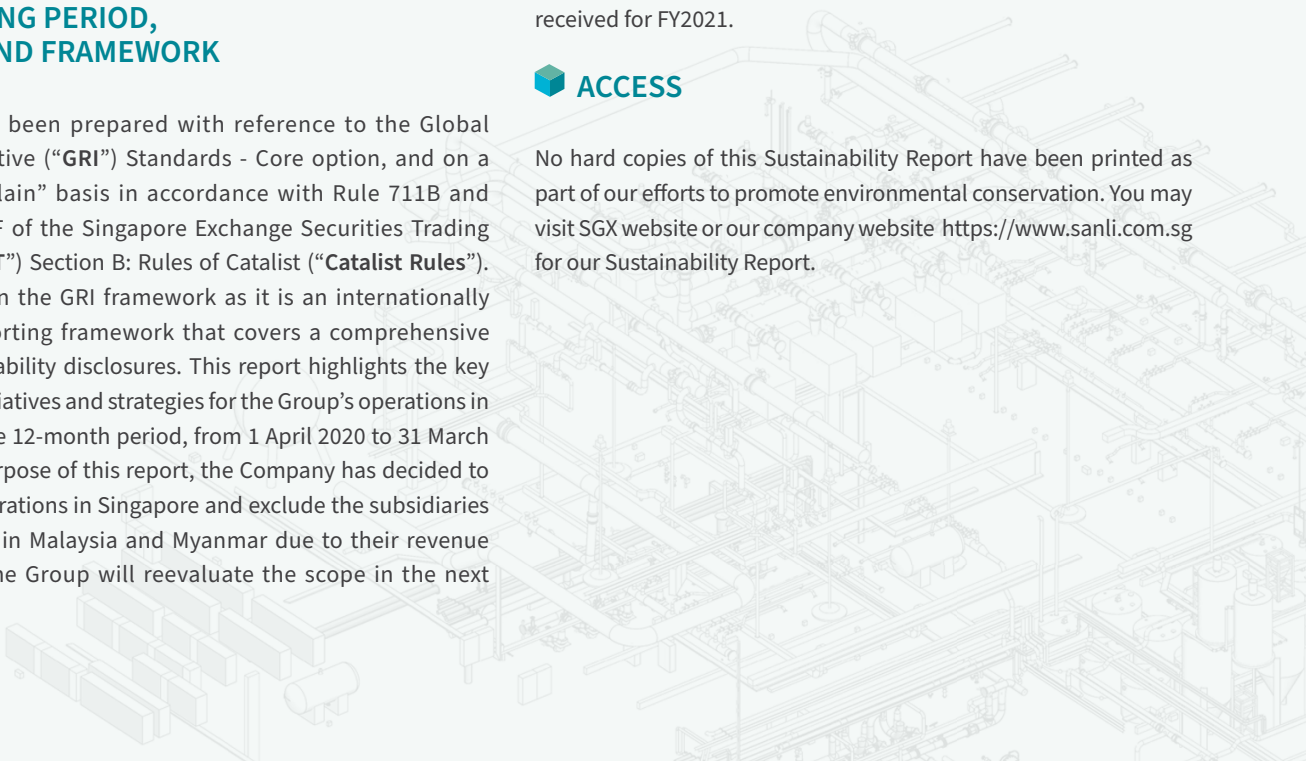

# ORGANISATIONAL PROFILE

Sanli Environmental Limited, together with its subsidiaries, was listed on the Catalist Board of the SGX-ST on 8 June 2017, pursuant to an initial public offering exercise. The Group’s operations and markets served are primarily located in Singapore with headquarter located at 28 Kian Teck Drive, Singapore 628845. The Group has made inroads into Myanmar in the past few years. The Group is hopeful that when Covid-19-related travel and movement restrictions are eventually lifted, we will be able to ramp up our regional expansion efforts, particularly by growing our operations in Myanmar as well as assessing opportunities in other parts of the region.

## OUR VISION:

To be a leading environmental solutions company capable of meeting the needs of tomorrow.

## OUR MISSION:

To provide reliable and cost-effective total solutions for water and waste management, driven by innovation and executional excellence.

## OUR CORE VALUES:

### Safety First

We believe that no job or task is so important that we can risk our colleagues’ and stakeholders’ lives for.

### Boldness

We dare to step into the unknown to create a better environment for our society.

### Be Different

We think out of the box when providing solutions for our clients.

### Integrity

We believe that honesty is the best policy to ensure a healthy and long-term relationship between our partners and us.

### Unity

We strive together as one family to achieve success.

We are an environmental engineering company in the field of water and waste management. Our expertise is in the design, supply, delivery, installation, commissioning, maintenance, repair and overhaul of mechanical and electrical equipment as well as process, instrumentation and control systems in wastewater treatment plants, water reclamation plants, NEWater plants, waterworks, service reservoirs, pumping stations and incineration plants.

Our business is divided into two main business segments:

## ENGINEERING, PROCUREMENT AND CONSTRUCTION (“EPC”)

- We provide engineering, procurement and construction services within the field of water and waste management.
- Our services include process upgrading of existing water treatment plants, upgrading of pumping station capacities, replacement of aged mechanical and electrical equipment, and design and build of various treatment process systems.
  - **WATER MANAGEMENT**  
Engineering solutions and services for the treatment of raw water and used water.
  - **WASTE MANAGEMENT**  
Engineering solutions and services for the treatment of refuse in incineration plants.

## OPERATIONS AND MAINTENANCE (“O&M”)

- We provide corrective and preventive maintenance services to ensure reliability and minimal disruptions to customers’ operations.

Backed by our strong engineering capabilities, we have the ability to integrate mechanical, electrical and process engineering expertise to provide customised cost- and time-efficient integrated engineering solutions and services to our customers.

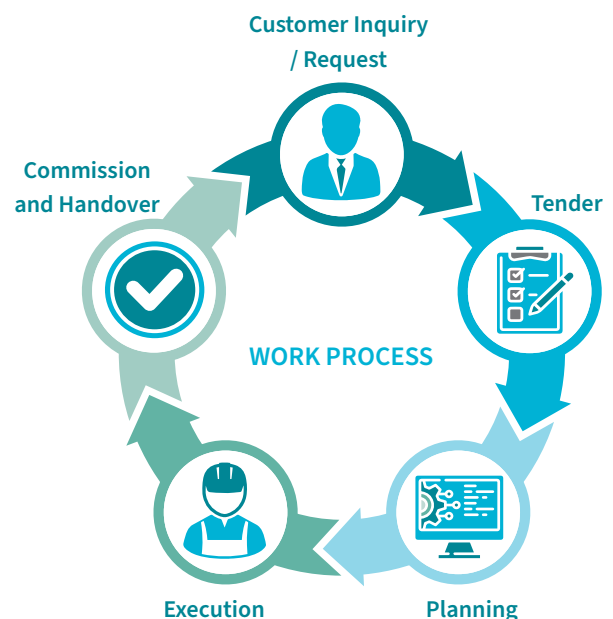

# SUSTAINABILITY APPROACH

## SANLI'S SUSTAINABILITY METHODOLOGY

At Sanli, we are committed to conduct our business in a responsible and sustainable manner. To achieve and maintain our sustainability goals, the Group articulates our values through the following approaches:



## SUSTAINABILITY GOVERNANCE

Strong governance is the key to a sustainable business. It is a continual challenge to successfully manage environmental and social issues. Sanli has incorporated this into our business model and implemented sustainable and responsible practices throughout the Group. We are committed to provide top-notch services to meet the relevant safety and environmental requirements set out by our customers and the regulatory bodies.

Sanli pays strict attention to enforcing good labour practices in all our operations. The Group provides various training opportunities for continuous employee development and this has been reflected in the quality and delivery of our services. We value our relationships with our clients and the wider community in which we operate, and these relationships forged have helped us through challenging times in the past. The Group strongly believes that in the long run, these efforts will be reciprocated through positive impacts on the Group's economic performance.

The Board takes overall responsibility in overseeing the Group's sustainability management. A sustainability committee, comprising of senior management including the Chief Financial Officer, Head of Human Resource and Head of Health, Safety and Environmental Department, is responsible for driving the Group's

overarching sustainability strategy and channeling the implementation of sustainability initiatives in the day-to day operations of business managers. These managers in their respective functions become responsible for implementation, measuring, monitoring and reporting back to the sustainability committee on the progress.

### Our 3 Year Performance

Throughout FY2021, we continue to comply in all material aspects of the principles and provisions of the Code of Corporate Governance 2018 (the 'Code 2018') and achieved the target we set last year. The following table shows the actual compliance status of the Code 2018 for FY2021, FY2020 and FY2019.

FY2021	FY2020	FY2019
Complied with the Code 2018 (Target met)	Complied with the Code 2018 (Target met)	Complied with the Code 2012 (Target met)

**OUR TARGET (FY2022)**  
Continue to meet all requirements that are expected of us by our stakeholders and continue to comply with Code 2018

## ENTERPRISE RISK MANAGEMENT

Sanli believes that Enterprise Risk Management ("ERM") is an integral part of good corporate governance as well as resource management. The ERM facilitates the Board in identifying and assessing key operational, financial, compliance and information technology risks with reference to the business goals, strategies and critical success factors of the Group. Under the ERM Framework, Management and executives of all levels are expected to constantly review the business operations and the operating environment to identify risk areas and ensure mitigating measures are promptly developed to minimise these risks. The ERM Framework outlines the Group's approach to managing enterprise-wide risks and sets out a systematic process for identifying, evaluating, monitoring, managing and reporting risks faced by the Group. Thus, it allows the Group to address the changes and the challenges in the business environment, reduce uncertainties and facilitate the shareholder value creation process on an ongoing basis.

### Our 3 Year Performance

In FY2021, we accomplished our target set last year, i.e., reviewed the ERM policies in FY2021 to ensure all relevant risks are identified, communicated and addressed timely.

# SUSTAINABILITY APPROACH

The following table shows the ERM review practices for FY2021, FY2020 and FY2019.

FY2021	FY2020	FY2019
Reviewed the ERM policies to ensure all relevant risks are identified, communicated and addressed timely (Target met)	Reviewed the ERM policies to ensure all relevant risks are identified, communicated and addressed timely (Target met)	Reviewed the ERM policies to ensure all relevant risks are identified, communicated and addressed timely (Target met)



**Our Target (FY2022)**  
Continue to review ERM policies annually and to ensure all relevant risks are identified, communicated and addressed timely

## BUSINESS ETHICS AND COMPLIANCE

When it comes to hiring, we take into serious consideration any conflict of interest. Our code of conduct clearly lays the Group’s expectations for our staff and spells out consequences for violating rules or not meeting expectations. In addition, we also have clear and fair grievance procedures for internal dispute resolution.

All of our staff are reminded of the importance of upholding the highest standards when it comes to business ethics. The Group regularly updates relevant staff with development in international

and local regulations. Sanli is proud to inform that it is in compliance, in all material aspects, with all environmental rules and regulations, anti-competitive practices and the Workplace Safety and Health Act.

The Board is of the view that cybersecurity and data privacy are important not just for compliance, but in safeguarding both the Group’s data and that of our customers. Sanli takes measures to guard against cyber risks, protecting confidential information for both our internal and external stakeholders. This also applies to our employment process where the privacy of all applicants is safeguarded and access to personal data is restricted to authorised personnel on a need-to-know basis.

### Our 3 Year Performance

For FY2021, we have achieved the target we set last year which was maintained zero incidents of non-compliance.

The following table shows the actual non-compliance with laws and regulations cases reported for FY2021, FY2020 and FY2019.

FY2021	FY2020	FY2019
0 (Target met)	0 (Target met)	0 (Target met)







**Our Target (FY2022)**  
0 Maintain zero incidents of non-compliance



# STAKEHOLDERS AND MATERIALITY

## STAKEHOLDERS ENGAGEMENT

We have identified our key stakeholders and material aspects that are instrumental to our business. The interests and requirements of our key stakeholders are taken into account when formulating corporate strategies. These key stakeholders include, but are not limited to, customers, suppliers, shareholders, employees, and regulators.

KEY STAKEHOLDERS	ENGAGEMENT PLATFORMS	FREQUENCY OF ENGAGEMENT	KEY CONCERNS RAISED
Employees 	Staff appraisal	Annually	Employee compensation and benefits, personal development
	Town hall session	Annually	
	Get-together session Badminton competitions	Semi-annually	
Customers 	Face-to-face / Virtual meetings and feedbacks	Daily	Quality of services, on-time completion
	Occasional site-visits	Ad-hoc	
Suppliers 	Face-to-face / Virtual meetings	Daily	Prompt payment, accurate specifications, selection of reliable suppliers. Disruption of supply chain due to COVID-19 and lockdowns imposed by Government
	Evaluation and feedback	Annually	
Shareholders 	Annual general meeting	Annually	Financial and operational performance of the Group, corporate governance and sustainability practices, business strategies of the Group
	Annual report	Annually	
	Corporate announcements and financial results announcements	Ad-hoc	
	Company website	Ad-hoc	
Regulators 	Occasional face-to-face meeting / inspections	Ad-hoc	Full-compliance to regulations
	E-mails	Ad-hoc	
	Surveys	Ad-hoc	

# STAKEHOLDERS AND MATERIALITY

We adopt both formal and informal channels of communication to understand the needs of our key stakeholders, so as to include and align the needs of the key stakeholders in our corporate strategies to achieve mutually beneficial relationships. These are stakeholders defined as having the most influence over and the highest level of interest in the Company's operations as set out below.

## CUSTOMERS

Customer satisfaction is one of the key focuses for our businesses. Engagement with customers, through sites meetings, allows us to receive timely, valuable feedback to improve our service standards.

## EMPLOYEES

Engagement with employees is conducted regularly to measure satisfaction level, gather feedback as well as discuss business strategy and organizational changes.

## SUPPLIERS

At Sanli, we work with reliable and credible suppliers and aim to form a long-standing and trusting relationship with such suppliers. In cases of disruption caused due to COVID-19, alternative actions will be taken upon further discussions within each business segment team.

## SHAREHOLDERS

We strive to maximise shareholder returns, maintain good corporate governance, and improve levels of transparency through financial and sustainability reporting and timely communication.

## REGULATORS

Obtain clarifications or understanding of the new or revised regulatory and industry standards and guidelines, seek advices from external consultants to ensure full compliance to the regulations.



# STAKEHOLDERS AND MATERIALITY

## MATERIAL ASPECTS ASSESSMENT

Our sustainability process begins with the identification of relevant aspects. Relevant aspects are then prioritised to identify material factors which are subject to validation. The result of this process is a list of material factors disclosed in this report. Process of which is shown below:

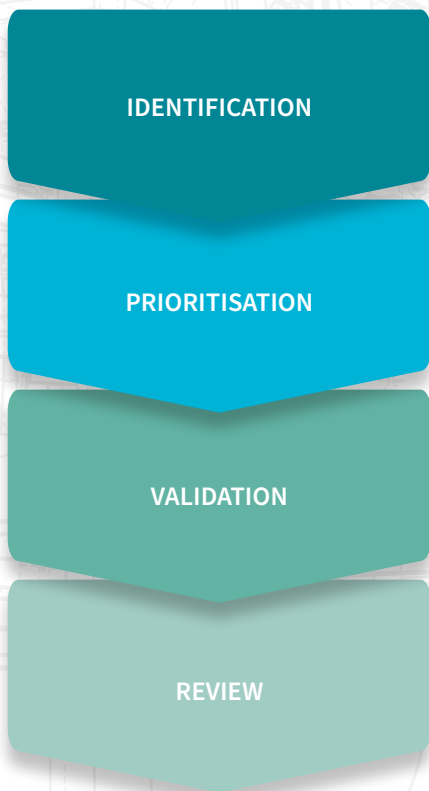

Materiality with respect to sustainability reporting, as defined by GRI standards, includes topics and indicators that reflect the organisation’s significant economic, environmental, and social impacts; and would substantively influence the assessments and decisions of stakeholders.

Having considered the topics of concerns and expectation of identified key stakeholders, the Sustainability Reporting Committee together with the Management have assessed and prioritized the material topics to focus on for the Group, as well as targets and commitments.

Applying the guidance from GRI, we have identified the following as our material factors:



### ECONOMIC

Economic Performance  
Anti-corruption



### ENVIRONMENTAL

Energy Consumption  
Environmental Compliance



### SOCIAL

Occupational Health and Safety  
Diversity and Equal Opportunity  
Local Communities  
Socioeconomic compliance



### GOVERNANCE

Sustainability Governance  
Enterprise Risk Management  
Business Ethics and Compliance

*Impact Boundary: Sanli Environmental Limited – Employees, Project Sites, Office, Community*

# ECONOMIC

## ECONOMIC PERFORMANCE

Sanli firmly believes that the financial sustainability of the Group is critical, and we are fully committed to the highest standards of corporate governance. The Group's basic principle is to ensure long-term profitability and shareholders' value, by taking into account the interests of all stakeholders, such as shareholders, employees, suppliers and society as a whole. Sanli will remain cautious with regards to market conditions and will continue to be vigilant in managing costs and improving operational efficiencies.

The Group's FY2021 revenue decreased by 9.8% to S\$60.5 million from S\$67.1 million in FY2020. Gross profit decreased by 40.7% to S\$4.4 million from S\$7.4 million in FY2020, with gross profit margin down by 3.7 percentage points to 7.3% (FY2020: 11.0%) mainly due to lower revenues from EPC segment and higher labour related costs incurred by both EPC and Q&M segments because of the COVID-19 pandemic. Overall, the Group's net profit for FY2021 was S\$0.53 million (FY2020: S\$0.42 million). With a net profit attributable to shareholders of S\$0.33 million (FY2020: S\$0.32 million), the earnings per share for FY2021 is 0.12 Singapore cents (FY2020: 0.12 Singapore cents).

For detailed financial results and commentary of the significant trends and competitive conditions of industry, please refer to the full year financial statements and dividend announcement for FY2021 as announced on 26 July 2021.

## ANTI-CORRUPTION

We recognise that any breaches of ethics and corruption can lead to significant reputational damage, legal consequences and loss of customers. Additionally, it puts the trust that we have built between our business and our stakeholders at great risk. We do not tolerate corruption in any form. This has been made clear to all of the Group's employees, suppliers and business partners. Dedicated whistleblowing hotlines, through both email and company website, are set up so that anyone wanting to report any business ethics issue can do so confidentially. Any report of corruption will be escalated to the attention of the Audit Committee.

### WHISTLEBLOWING POLICY

Our whistleblowing policy provides a transparent channel for employees to report any concern or complaint regarding any improper accounting or financial matters, internal controls, disclosure of information, conflict of interest, insider trading, or any other areas involving fraud, corruption and misconduct of employees. The public, customers and stakeholders can also report possible improprieties or provide other feedbacks through the Company's website at <https://www.sanli.com.sg>.

### Our 3 Year Performance

For FY2021, our Group had accomplished and met the target set in FY2020 to have zero (FY2020: Nil) reported incidents of corruption and whistleblowing cases.

The following table shows the actual reported incidents of corruption and whistleblowing cases for FY2021, FY2020 and FY2019.

FY2021	FY2020	FY2019
0 (Target met)	0 (Target met)	0 (Target met)

### OUR TARGET (FY2022)



# 0

- Regularly review our policies on whistleblowing and anti-corruption.
- Maintain zero reported incidents of anti-corruption and whistleblowing.

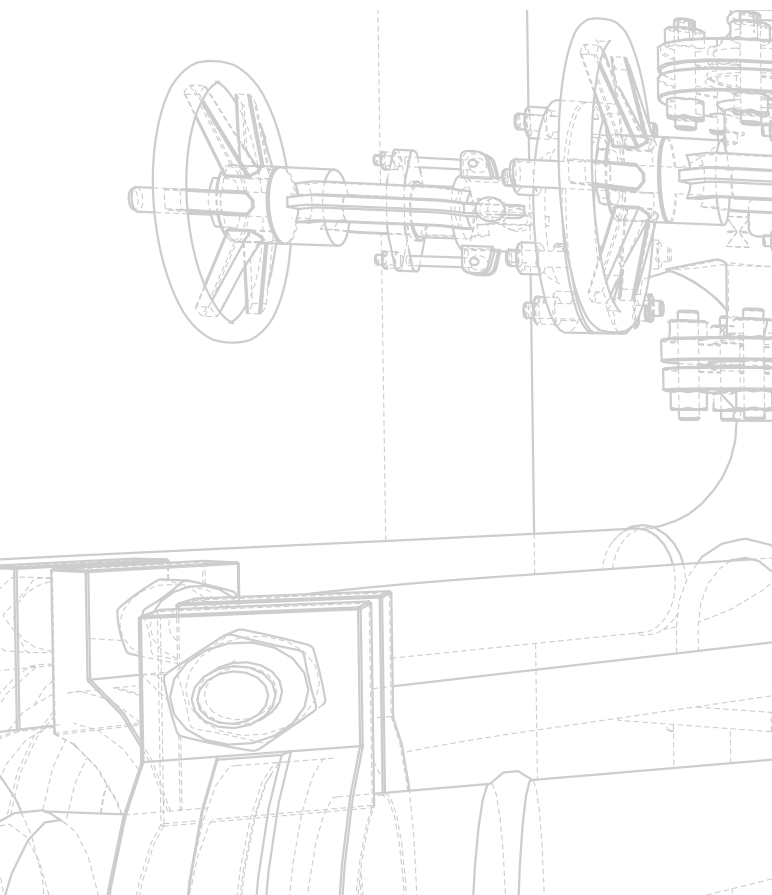

# ENVIRONMENTAL

We endeavor to minimise the potential impact of our operations on the environment by putting in place proper processes for waste reduction and waste management. We encourage the use of renewable materials and resources, and where possible, reduce waste through reusing and recycling. We avoid any unnecessary use of hazardous materials and products and take all reasonable steps to protect the environment when such materials must be used, stored or disposed of.

Sanli aims to minimise the environmental impacts of its operations by having the following measures in place to protect the environment.

## 1. CERTIFICATION

We have attained ISO 14001-2015 renewal certificate, which is the standard required for Effective Environmental Management System and we have fully complied with zero non-compliance.

## 2. PROMOTING GREEN PRACTICE – GREEN BUILDING (HEADQUARTER LOCATED AT 28 KIAN TECK DRIVE)

- a. We have built a Lift Green Wall with an area of L2400mm X H13400mm and a two-sided of HyGroWall with an area of L6100mm X H3000mm at the office reception area.
- b. We have maintained the effort to fulfill the Skyrise Greenery Incentive Scheme for 4 years since FY2018.
  - The Greenery helped to clean outside air, pollutants, and dust that helps to offset the carbon footprint of people and fuel emissions.
  - The Greenery also helped to reduce the Volatile Organic Compounds' impact on indoor air quality and other harmful toxins such as benzene. It also acted as a sound proofing barrier and encouraged natural cooling that effectively reduced the heat transfer through building walls into the interior building space, leading to possible energy savings.
  - The system has improved the air ventilation within the premises by providing better air quality.

## 3. PAPER

In our efforts to reduce paper usage, we have provided our staff with tips on paper conservation such as printing only where necessary, printing on both sides of the paper, and reusing and recycling used paper. Recycling boxes were also conveniently placed beside the photocopier machines.

## ENERGY CONSUMPTION

We encourage the use of energy-efficient lightings and green label photocopiers in the office. On our premises, we used LED lightings and installed auto light-on system in level one in our effort to reduce the carbon footprint.

### Our 3 Year Performance

In FY2021, our total energy consumption for Headquarters (HQ) offices was 81,680kWh (FY2020: 108,933kWh) The decrease in energy consumption as compared with FY2020 was mainly due to staff alternating between working from home and the office during the Covid-19 pandemic. Nevertheless, we target to improve electricity saving by 1% in FY2022 based on pre-Covid consumption level. We had put up stickers at all switch ports to remind our employees to switch off power sources after use.

FY2021	FY2020	FY2019
Electricity Saving by 1% (Target met)	N/A	N/A



### OUR TARGET (FY2022)

Improve electricity saving by 1% based on pre-Covid consumption level.

## ENVIRONMENTAL COMPLIANCE

Here at Sanli, compliance with relevant Codes and Regulations on environmental issues is of utmost importance and we take steps at all our work sites to ensure the requirements are met throughout the duration of the projects.

### Our 3 Year Performance

In FY2021, we achieved our target of zero (FY2020: Nil) incident of non-compliance with laws and regulations in FY2020.

The following table shows the actual non-compliance with laws and regulations cases reported for FY2021, FY2020 and FY2019.

FY2021	FY2020	FY2019
0 (Target met)	0 (Target met)	0 (Target met)



### OUR TARGET (FY2022)

# 0

Maintain zero incident of non-compliance with laws and regulations

# SOCIAL

## OCUPATIONAL HEALTH AND SAFETY

Our employees' safety and health at the workplace is one of our top priorities, and our ultimate goal is to have a zero fatal accident workplace. We are committed to managing and reducing safety and health risks through effective risk management.

### Our 3 Year Performance

In FY2021, we are pleased to confirm that we have reached our target set in FY2020 that zero (FY2020: nil) fatal accidents were reported in FY2021.

The following table shows the actual fatal accidents reported for FY2021, FY2020 and FY2019.

FY2021	FY2020	FY2019
0 (Target met)	0 (Target met)	0 (Target met)

### OUR TARGET (FY2022)



# 0

- Zero incident of health, safety and environment non-conformity, accident and ill health.
- Zero fatal accidents

Our Workplace, Health & Safety department is independent from the operational departments and is responsible for the monitoring of the workplace to provide a safe working environment for all our staff and clients. A toolbox briefing, in accordance with the Workplace Safety and Health Council's Effective Toolbox Meeting guideline is held at each worksite every morning. A toolbox talk is an informal safety meeting that is part of the Group's overall safety program, which covers special topics on safety aspects related to a specific job. Toolbox meetings are generally conducted at the job site prior to the commencement of a job or work shift. Meetings are normally short in duration and cover topics such as workplace hazards, and safe work practices. It is one of the very effective methods to refresh workers' knowledge on workplace safety, cover last minute safety checks, and exchange information with experienced workers.

We have established a strict set of workplace, health and safety management policies applicable to our project managers, engineers, supervisors, foremen, workers and subcontractors for all projects. These policies cover all stages of our projects, from the time we occupy the worksites, up to the point of completion of the projects. In addition, all environmental aspects and occupational health safety hazards which are within our control or under our

management, as well as those that we cannot control or directly manage but are expected to affect our projects, are covered in the policies.

Our Workplace, Health and Safety department is responsible for ensuring that the safety measures which we have put in place are adhered to. Such measures include:



Conducting periodic and necessary risk assessments for all our projects to identify the risks and gaps and implementing mitigating procedures in order to achieve an accident-free environment or minimise risks to an acceptable level.



Conducting regular safety meetings and providing sufficient management support and resources to plan, implement and execute safety measures in compliance with workplace health and safety legislations and other requirements which include directives, guidelines and standards prescribed by our Group.



Allocating safety supervisors to our projects, where relevant, and conducting regular worksite inspections as well as tools and equipment checks.



Improving the competency of our employees and cultivating good safety habits through proper training, instruction and guidance and ensuring that workplace safety and health matters are effectively communicated to all employees.



Monitoring the effectiveness of risk control measures which have been implemented and conducting a third-party audit or an internal review to ensure that safety measures are adhered to.

### Covid-19 Control Measure

The Group has implemented Covid-19 control measures in accordance with Minister of Manpower and Building and Construction Authority advisories such as work from home (alternate week) arrangement for office staff, segregation of the employees, restriction of physical meetings at the workplace, monitoring of health program, safe distancing and other practices as per the requirements.

There were incidences where some of our employees staying in the dormitories infected Covid-19. The Company has provided full support and assistance to them for their medical care and recovery. We are pleased to report that all the infected employees have since recovered.

# SOCIAL

As a testament to our commitment in maintaining high safety standards, we have been awarded the following certifications:

Date of issue: 06/02/2020



**bizSAFE**  
STAR  
CERTIFICATE

The Workplace Safety and Health Council is pleased to certify that

**SANLI M&E ENGINEERING PTE. LTD.**

---

has fulfilled the requirements to attain bizSAFE Level Star  
This certificate is valid till 21/03/2022



**Patrick Han**  
General Manager  
Workplace Safety and Health Council

Certificate No. E03950



**CERTIFICATE**  
No. SCS 8871-1

certifies that:

**Sanli M&E Engineering Pte Ltd**  
28 Kian Teck Drive Singapore 628845

---

operates a management system that has been assessed as conforming to:



**ISO 9001 : 2015**

for the scope of activities:  
Mechanical & Electrical Engineering Services including Design

---

Issue date: **29 March 2020**  
Valid until: **28 March 2023** (Subject to adherence to the agreed ongoing programme, successful endorsement of certification following each audit and compliance with the terms and conditions of certification.)  
Original date of certification: **29 March 2011**

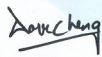
**Dave CHENG LOON** Managing Director

SOCOTEC Certification Singapore Pte Ltd  
60 Albert Street #13-03, 05 Albert Complex  
SINGAPORE 189369  
www.socotec-certification-international.sg

The use of the SAC accreditation mark indicates accreditation in respect of those activities covered by the accreditation certificate number 05-1999-05



**CERTIFICATE**  
N° CN/ 88710-1

certifies that:

**Sanli M&E Engineering Pte Ltd**  
28 Kian Teck Drive Singapore 628845

---

operates a management system that has been assessed as conforming to:

**ISO 45001 : 2018**

for the scope of activities:  
Mechanical and electrical engineering services and scaffolding works.

---

Issue date: **22 March 2019**  
Valid until: **21 March 2022** (Subject to adherence to the agreed ongoing programme, successful endorsement of certification following each audit and compliance with the terms and conditions of certification.)

**Dave CHENG LOON** Managing Director



SOCOTEC Certification Singapore Pte Ltd  
60 Albert Street #13-03, 05 Albert Complex  
SINGAPORE 189369  
www.socotec-certification-international.sg

The use of the SAC accreditation mark indicates accreditation in respect of those activities covered by the accreditation certificate number 05H-2009-01



**CERTIFICATE**  
N° CN/ 8871B

certifies that:

**Sanli M&E Engineering Pte Ltd**  
28 Kian Teck Drive Singapore 628845

---

operates a management system that has been assessed as conforming to:

**ISO 22301 : 2012**

for the scope of activities:  
Mechanical and electrical engineering services including design.

---

Issue date: **26 August 2018**  
Valid until: **25 August 2021** (Subject to adherence to the agreed ongoing programme, successful endorsement of certification following each audit and compliance with the terms and conditions of certification.)  
Original date of certification: **26 August 2015**

**Dave CHENG LOON** Managing Director





SOCOTEC Certification Singapore Pte Ltd  
60 Albert Street #13-03, 05 Albert Complex  
SINGAPORE 189369  
www.socotec-certification-international.sg

The use of the SAC accreditation mark indicates accreditation in respect of those activities covered by the accreditation certificate number 8C-2019-01

# SOCIAL

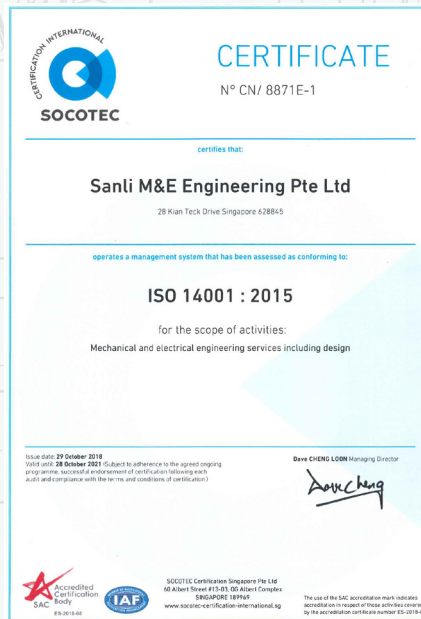
As a testament to our commitment in maintaining high safety standards, we have been awarded the following certifications: (cont'd)



# SOCIAL

## DIVERSITY AND EQUAL OPPORTUNITY

Sanli's staff recruitment and annual appraisals are conducted based on performance, work attitude, cooperation with other staff and workers and efficiency and effectiveness of work. The Group does not discriminate one's race, age, gender, religion, ethnicity, disability or nationality. In FY2021, we have a staff strength of 334 (FY2020: 327) full-time employees and zero (FY2020: 1) temporary/contractual employees.

The Group regards our employees as our greatest asset. It is because of them that we are able to achieve success and growth. It is important for us to maintain continuous employee development, provide competitive employee benefits and ensure fair and safe working conditions, so that we retain our staff and are positioned as an attractive organisation for new talent. Remuneration policies and packages are reviewed regularly to ensure that the compensation and benefits are in line with the market and that the employees are rewarded for their contributions, thus aligning the interests of the employees to those of the Group's. Variable bonuses are granted to eligible employees based on the individual employee's contribution to the Group, profitability of the Group, current economic/ business situation, government's wage guidelines, and internal and external salary equality. Contributions to retirement benefit schemes are offered as part of the remuneration package in accordance to The Retirement Age Act. The official retirement age is 62 years old but may be extended based on mutual agreement between the Company and the employee. In FY2021, we have 11 (FY2020: 8) employees that are above 62 years old. The Group will also continue to recruit and groom young talent at the same time acquiring senior experienced professional e.g. Retirees.

## GENDER

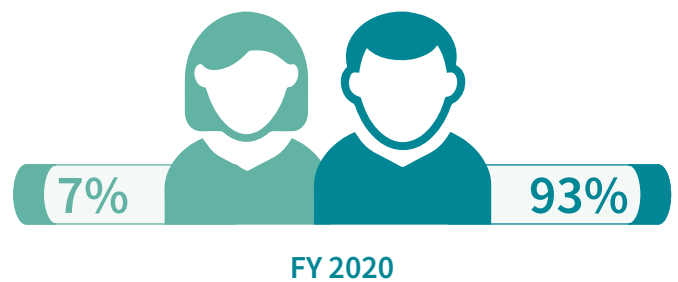

The ratio of female employees in the Group and our industry is relatively low due to the nature of our business. Our female employees represent 8% of our total workforce.

### FY 2021

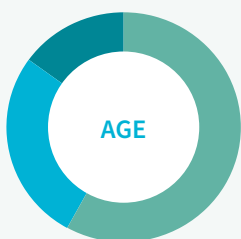

Age Group	Percentage	Count
< 30 years	27%	(91)
30-50 years	58%	(192)
> 50 years	15%	(51)



Nationality	Percentage	Count
Bangladeshi	32%	(106)
Indian	28%	(92)
Singaporean	18%	(61)
Malaysian	15%	(50)
Others	7%	(25)

### FY 2020

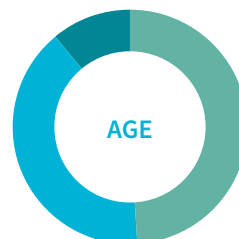

Age Group	Percentage	Count
< 30 years	40%	(133)
30-50 years	49%	(160)
> 50 years	11%	(35)



Nationality	Percentage	Count
Bangladeshi	39%	(127)
Indian	25%	(81)
Malaysian	19%	(63)
Singaporean	11%	(36)
Others	6%	(21)

# SOCIAL

### Our 3 Year Performance

In FY2021, there were no (FY2020: nil) reported incidents of complaints on discrimination.

The following table shows the actual complaints on discrimination reported for FY2021, FY2020 and FY2019.

FY2021	FY2020	FY2019
0 (Target met)	0 (Target met)	0 (Target met)

**OUR TARGET (FY2022)**



**0** Zero complaints on discrimination and continue to have diversity and equal opportunity for all employees.

### LOCAL COMMUNITIES

While achieving business goals is important, Sanli aims to make a positive impact and contribute to the society. However, there were no social activities and charitable events carried out by the group in FY2021 due to Covid-19 pandemic. All the public events and activities were restricted by Singapore regulations to ensure safe distancing and limit the spread of the virus.

### Our 3 Year Performance

In FY2021, we did not achieve the target we set last year due to Covid-19.

The following table shows our targets and performance for FY2021, FY2020 and FY2019.

FY2021	FY2020	FY2019
No charity events conducted due to Covid-19. (Target not met)	Conducted Charity Event (Target met)	Conducted Charity Event (Target met)

**OUR TARGET (FY2022)**



Continue to seek opportunities to contribute and foster a corporate culture that cares about giving back to the community. (Subject to situation of Covid-19 and prevailing laws imposed by government)

### SOCIOECONOMIC COMPLIANCE

We pride ourselves in having good corporate governance and observing compliance with applicable laws and regulations. Sanli is committed to conduct the business with integrity and to safeguard the interest of all our stakeholders, both internal and external.

### Our 3 Year Performance

In FY2021, we have achieved our target of having no (FY2020: Nil) reported incidents of non-compliance.

The following table shows the actual reported incidents of non-compliance reported for FY2021, FY2020 and FY2019.

FY2021	FY2020	FY2019
0 (Target met)	0 (Target met)	0 (Target met)

**OUR TARGET (FY2022)**



**0** Zero incident of non-compliance and continue to comply with socioeconomics laws and regulation.

### MEMBERSHIPS





## GOVERNANCE



The Board and the Management of Sanli commit to the best practices of the corporate governance to ensure sustainability of the Group's operations. We believe that the constant drive to upkeep corporate excellence will allow us to establish a more transparent, accountable and equitable system, thereby increasing the value of the Company and the value to our shareholders. For more details of the Group's Corporate Governance Report, please refer to pages 3 to 4 and the Group's annual report to be published on 14 September 2021 through SGXNet.

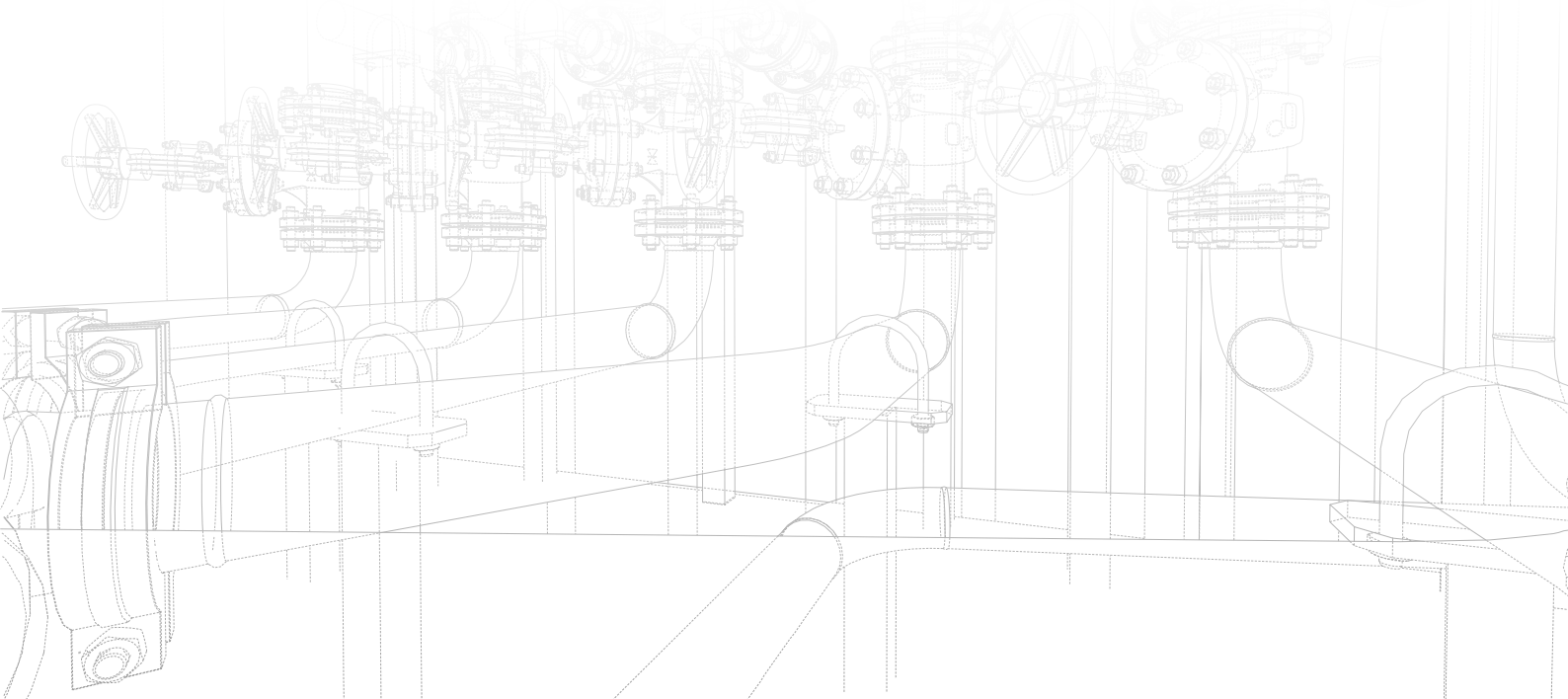

# GRI STANDARDS CONTENT INDEX

GRI STANDARD	DISCLOSURE	REFERENCE / DESCRIPTION
<b>GRI 101:</b> Foundation 2016		
<b>GENERAL DISCLOSURE</b>		
<b>GRI 102:</b> General Disclosures	102-1	Name of organisation Sanli Environmental Limited
	102-2	Activities, brands, products and services SR: Organization Profile, page 2
	102-3	Location of headquarters SR: Organization Profile, page 2 AR 2020: Corporate Information, page 14
	102-4	Location of operations SR: Organization Profile, page 2 AR 2020: CEO's message, pages 2-3
	102-5	Ownership and legal form AR 2020: Notes to Financial Statements, page 87
	102-6	Markets served SR: Organization Profile, page 2 AR 2020: CEO's message, pages 2-3
	102-7	Scale of the organisation SR: Organization Profile, page 2 AR 2020: Financial Review, pages 4-5
	102-8	Information on employees and other workers SR: Social, pages 13-14
	102-9	Supply chain SR: Organizational Profile, page 2
	102-10	Significant changes to the organisation and its supply chain None
	102-11	Precautionary Principle or approach Sanli supports the intent of the Precautionary Principle, but has not expressed a specific commitment.
	102-12	External initiatives SR: Social, page 14
	102-13	Membership of associations SR: Membership, page 14
	102-14	Statement from senior decision maker SR: Message from our Board of Directors, page 1
	102-16	Values, principles, standards and norms of behavior SR: Organizational Profile, page 2 AR 2020: Corporate Profile, page 1
	102-18	Governance structure SR: Sustainability Approach, pages 3-4 AR 2020: Corporate Governance Report, pages 16-42
	102-40	List of stakeholder groups SR: Stakeholders and Materiality, pages 5-6
	102-41	Collective bargaining agreements None
	102-42	Identifying and selecting stakeholders SR: Stakeholders and Materiality, pages 5-6
	102-43	Approach to stakeholder engagement SR: Stakeholders and Materiality, pages 5-6
	102-44	Key topics and concerns raised SR: Stakeholders and Materiality, page 5
	102-45	Entities included in the consolidated financial statements Sanli M&E Engineering Pte Ltd, Sanli E&C Pte Ltd, Sanli M&E Engineering Sdn Bhd and Sanli Environmental (Myanmar) Co Ltd AR 2020: Notes to Financial Statements, page 87

# GRI STANDARDS CONTENT INDEX

GRI STANDARD	DISCLOSURE	REFERENCE / DESCRIPTION	
<b>GENERAL DISCLOSURE</b>			
<b>GRI 102:</b> General Disclosures	102-46	Defining report content and topic boundaries	SR: Message from our Board of Directors, page 1
	102-47	List of material topics	SR: Stakeholders and Materiality, page 7
	102-48	Restatement of information	None
	102-49	Changes in reporting	None
	102-50	Reporting period	SR: Message from our Board of Directors, page 1
	102-51	Date of most recent previous report	25 September 2020
	102-52	Reporting cycle	Annual
	102-53	Contact point for questions about the report	SR: Message from our Board of Directors, page 1
	102-54	Claims if reporting in accordance with the GRI Standards	SR: Message from our Board of Directors, page 1
	102-55	GRI content index	SR: GRI Standard Content Index, pages 16-17
102-56	External Assurance	The Company may consider seeking external assurance in the future.	
<b>MATERIAL TOPICS</b>			
<b>GRI 201:</b> Economic performance	201-1	Direct economic value generated and distributed	SR: Economic, page 8
<b>GRI 205:</b> Anti-corruption	205-1	Operations assessed for risks related to corruption	SR: Economic, page 8
<b>GRI 302:</b> Energy	302-1	Energy consumption within the organization	SR: Environmental, page 9
<b>GRI 307:</b> Environmental compliance	307-1	Non-compliance with environmental laws and regulations	SR: Environmental, page 9
<b>GRI 403:</b> Occupational health and safety	403-1	Occupational health and safety management system	SR: Social, pages 10-12
	403-5	Worker training on occupational health and safety	
<b>GRI 405:</b> Diversity and equal opportunity	405-1	Diversity of governance bodies and employees	SR: Social, pages 13-14
<b>GRI 413:</b> Local Communities	413-2	Operations with local community engagement, impact assessments, and development programs	SR: Social, page 14
<b>GRI 419:</b> Socioeconomic Compliance	419-1	Non-compliance with laws and regulations in the social and economic area	SR: Social, page 14



**SANLI ENVIRONMENTAL LIMITED**

(Incorporated in the Republic of Singapore on 27 February 2017)

(Company Registration No. 201705316M)

28 Kian Teck Drive  
Singapore 628845  
Tel: (65) 6578 9269  
[www.sanli.com.sg](http://www.sanli.com.sg)